



The principle of structure

The PS110 series pressure switches use film (low pressure) or piston (high pressure) measuring elements for gas or liquid pressure detection. When the pressure reaches the set point, the moving part triggers a microswitch supported by a spring. Plate mount is available. Measurement of neutral gas, air, lubricating oil, oil and other media.

The characteristics of

- ◆ The highest pressure 80bar
- ◆ Set range from 0.5... 2 bar to 2... 20bar
- ◆ High repeatability
- ◆ Anodized aluminium shell
- ◆ Contact capacity up to 250Vac,0.6A
- ◆ Compact design, compact size
- ◆ Gas liquid dual purpose type
- ◆ SPDT output (normally open + normally closed)

The wiring diagram

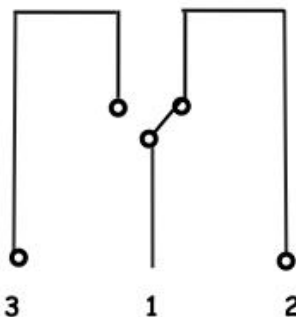

Technical parameters

Measuring the dielectric	Liquid or gas
Pressure adjustment range	See technical parameters for details.
repetitive	± 3% (related to set point)
Output way	Gold-plated contact micro switch SPDT (normally open + normally closed)
The switch capacity	
The biggest	250VAC,3A
No signal lamp	30VDC,2A
With the signal lamp	24-250V,0.6A
Adjust the way	Hexagon socket screw
Switching action frequency	MAX.100 beats/min
The environment temperature	-20...85
Medium temperature	-20...80
material	
The shell	Anodic aluminium oxide
Touch the liquid material	NBR, aluminum
Process connection	Aluminum/steel/stainless steel optional
Round way	Solenoid valve connector

Size chart

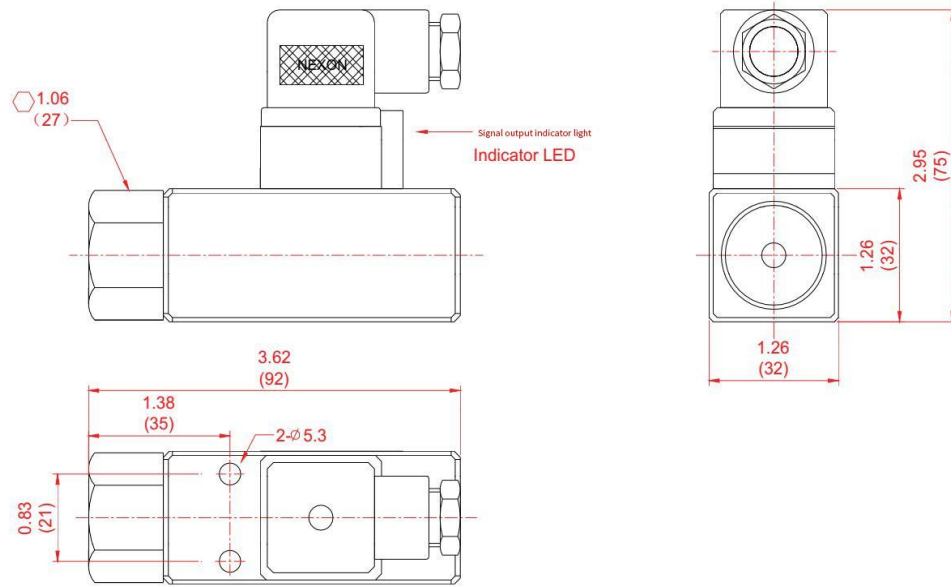

Selection table

PS110	1	PT14	F	L	detail ed	
PS110						Maximum pressure bar (psi)
	1				The adjustable range : 0.5...2bar(7.25...29psi)	80(1160)
	2				The adjustable range : 1.5...8bar(21.75...116psi)	80(1160)
	3				The adjustable range : 2...20bar(7.25...290psi)	80(1160)
		PT14			PT1/4Threaded connections	
			F		Internal thread	
				L	Shell material: anodized aluminum	

*Specific can be customized according to customer requirements